

assembly plan (type: C103)

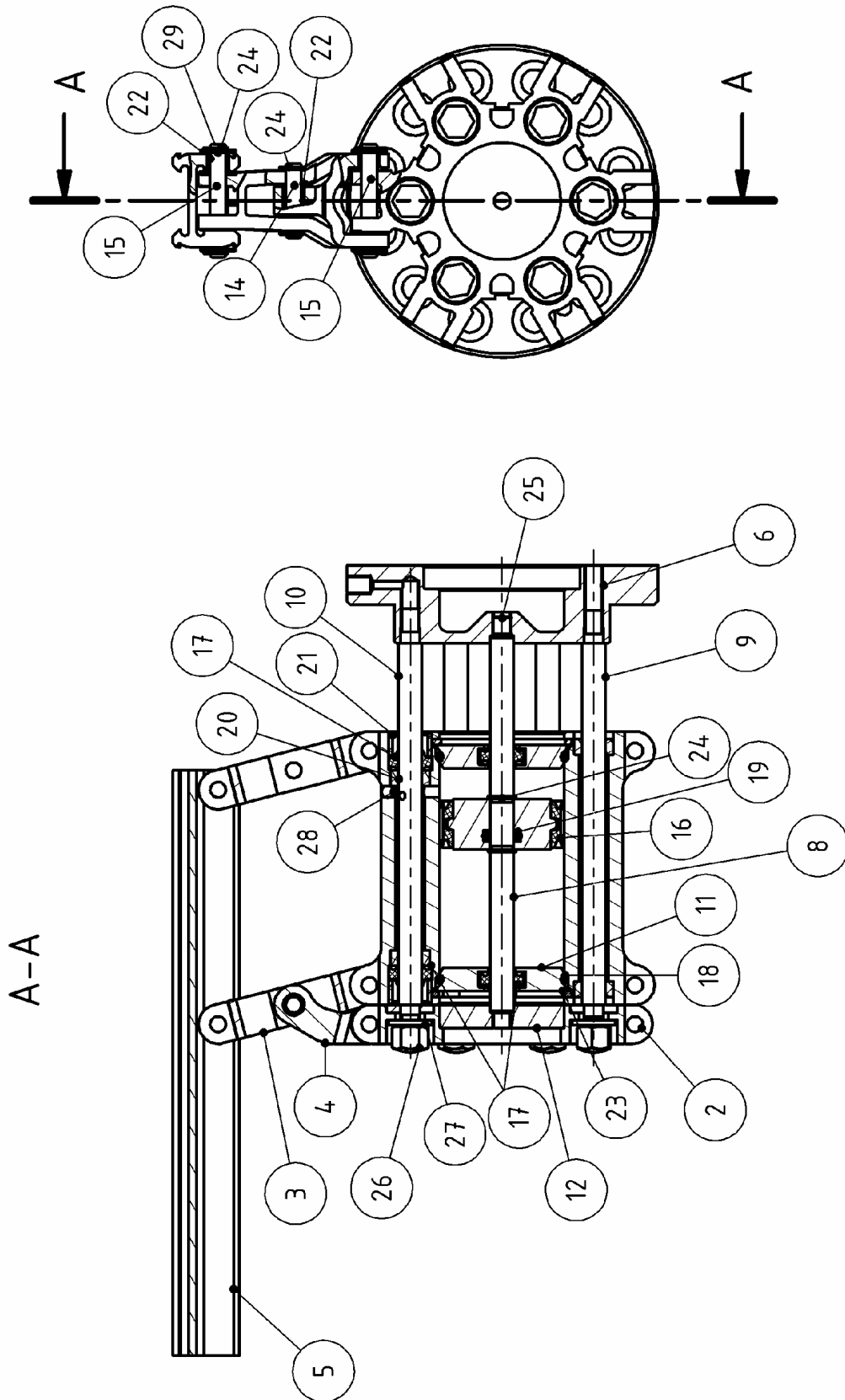

address:

GMG – Gesellschaft für modulare
Greifersysteme mbH
Rodinger Weg 8H • D-59494 Soest
Germany

phone:

+49 (0)2921 - 4062

fax:

+49 (0)2921 - 4042

e-mail:

info@gmg-system.com

homepage:

http://www.gmg-system.com

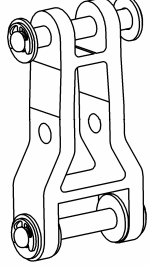
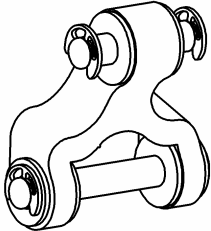
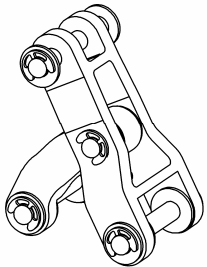
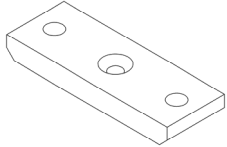
Pos. 4 + 5		Link, Crank, Crank Mechanism, Counter Plate		
Article	Component	Ident.	Scope of Delivery	
Link	02	LE04	Link (3), Slide Bearing (22), Bearing Pins (15), Washer and Circlips.	
Crank	03	KU04	Crank (4), Slide Bearings (22) Bearing Pins (14 + 15), Washer and Circlips	
Crank Mechanism	51	KT04	Link (3), Crank (4), Slide Bearings (22) Bearing Pins (14 + 15), Washer and Circlips	
Counter Plate	05	GP03	Counter Plate for shoe attachment. Only for fingers with finger length F=0 and standard bore template.	

Order Number:

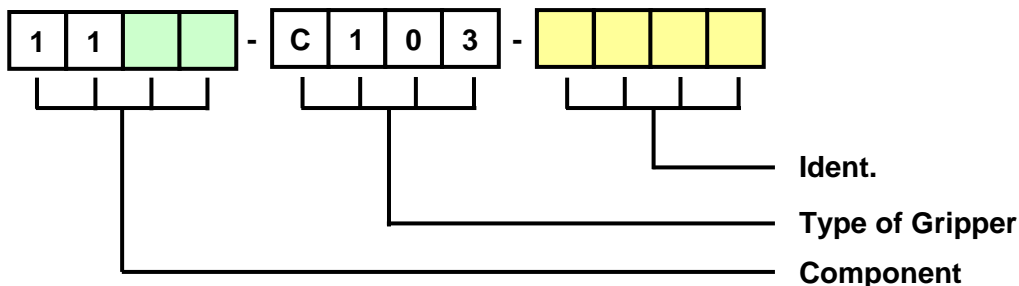

address:

GMG – Gesellschaft für modulare Greifersysteme mbH
 Rodinger Weg 8H • D-59494 Soest
 Germany

phone:

+49 (0)2921 - 4062

fax:

+49 (0)2921 - 4042

e-mail:

info@gmg-system.com

homepage:

http://www.gmg-system.com

Pos. 6			Finger			
Finger Length			Finger Movement			
Length Dimension (L) [mm]	Length Dimension (F) [mm]	Ident.	Finger Movement	Bore Dimension		Ident.
				(H) [mm]	(G) [mm]	
70	0	000	parallel open parallel close	60	5	A
90	20	020				
110	40	040	parallel open swiveling close	80		B
130	60	060				
150	80	080	swiveling open swiveling close	100		C
Special Legth		(F) in mm			Finger Type	
			Without Bore		00	
			With Bore		01	

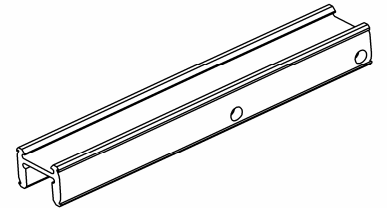

Order Number:

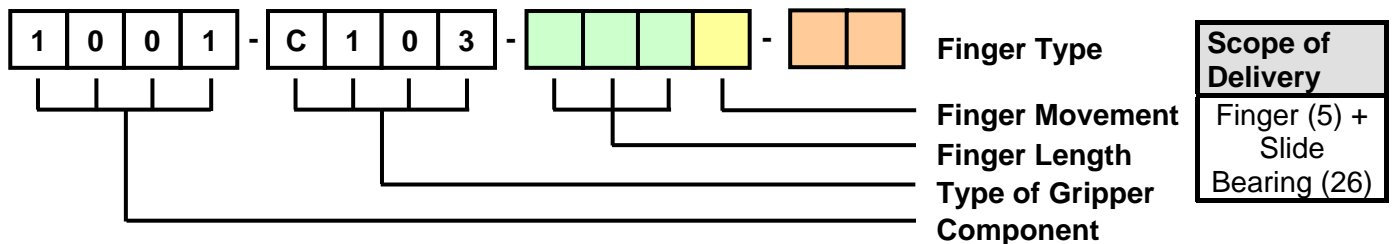

Pos. 14, 15		Bearing Pins	
-------------	--	--------------	--

Article	Component	Ident.	Scope of Delivery
Bearing Pin	01	B041	Bearing Pin (14), Washer and Circlips (22)
Bearing Pin	02	B042	Bearing Pin (15), Washer and Circlips (22)

Order Number:

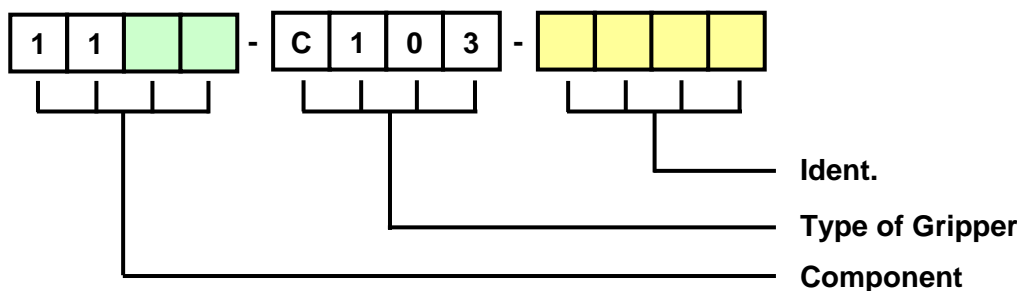

Pos. 4, 5, 6 Finger Mechanism

Finger Length			Finger Movement			
Length Dimension		Ident.	Finger Movement	Bore Dimension		Ident.
(L) [mm]	(F) [mm]			(H) [mm]	(G) [mm]	
70	0	000	parallel open parallel close	60	5	A
90	20	020				
110	40	040	parallel open swiveling close	80		B
130	60	060				
150	80	080	swiveling open swiveling close	100	C	
Special Length		(F) in mm		Finger Type		
			Without Bore		00	
			With Bore		01	

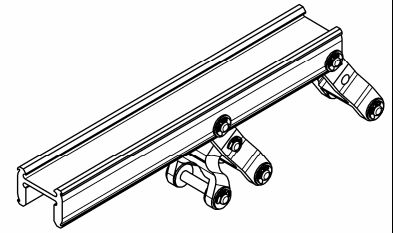

Bestellnummer:

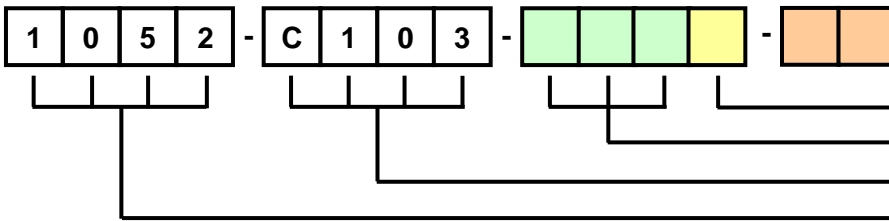

Finger Type

Finger Movement

Finger Length

Type of Gripper

Component

Scope of Delivery
Finger (5), Link (3), Crank (4), Slide Bearing (22), Bearing Pin (14 + 15), Washer and Circlip.

Operating Unit

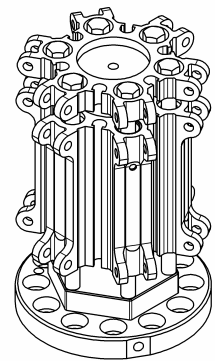
Pos.	Article	Order Number: 1079-C103-BE03
1-2, 6-13, 16-21, 23-29	Operating Unit	

address:

GMG – Gesellschaft für modulare Greifersysteme mbH
 Rodinger Weg 8H • D-59494 Soest
 Germany

phone:

+49 (0)2921 - 4062

fax:

+49 (0)2921 - 4042

e-mail:

info@gmg-system.com

homepage:

http://www.gmg-system.com

Spare Part Kit 1 (Piston Unit)

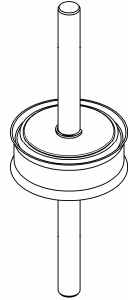
Pos.	Article	Quantity	Order Number: 1080-C103-KE03
7	Piston	1	
8	Piston Rod	1	
16	Piston Sealing	1	
19	O-Ring	1	
24	Circlip	2	

Spare Part Kit 2 (Cylinder Cover)

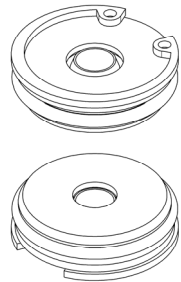
Pos.	Article	Quantity	Order Number: 1081-C103-ZD03
11	Cylinder Cap	2	
17	Seal and Stripper	2	
18	O-Ring	2	
24	Circlip	2	

Spare Part Kit 3 (Sliding Rods)

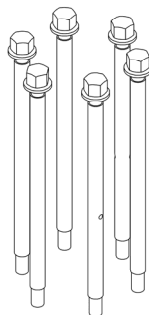
Pos.	Article	Quantity	Order Number: 1082-C103-FS03
10	Sliding Rod with Bore	2	
9	Sliding Rod	4	
26	Cap Nut	6	
27	Spring Washer	6	

address:

GMG – Gesellschaft für modulare Greifersysteme mbH
 Rodinger Weg 8H • D-59494 Soest
 Germany

phone:

+49 (0)2921 - 4062

fax:

+49 (0)2921 - 4042

e-mail:

info@gmg-system.com

homepage:

http://www.gmg-system.com

Seal Kit 03

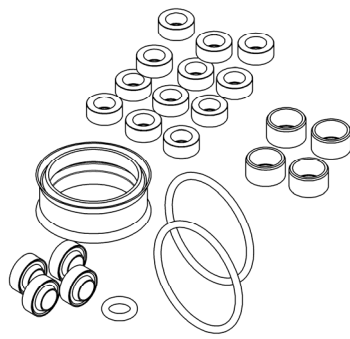
Pos.	Article	Quantity	Order Number: 1090-C103-DS03
16	Piston Seal	1	
17	Seal and Stripper	6	
18	O-Ring	2	
19	O-Ring	1	
20	Slide Bearing	12	
21	Seal Holding Ring	4	

Proximity Switch

Scope of Delivery	Order Number:
<i>Proximity Switch (PNP) with Extension</i>	1049-C103-PN01
<i>Proximity Switch (PNP) without Extension</i>	1049-C103-PN00

Proximity Switch Kit

Scope of Delivery	Order Number:
<i>1 Proximity Switch (PNP) with Extension, Magnetic Carrier, Fixation Bar for 2 proximity switches minimum, fixing screws</i>	1050-C103-PN01
<i>1 Proximity Switch (PNP) without Extension, Magnetic Carrier, Fixation Bar for 2 proximity switches minimum, fixing screws</i>	1050-C103-PN00

Mounting Elements for Proximity Switch

Scope of Delivery	Order Number:
<i>Magnetic Carrier, Fixation Bar for 2 proximity switches minimum, fixing screws</i>	1005-C103-BESG

We only deliver to the INCOTERMS latest edition.
 All printing and clerical errors are subject to correction without liability!
 Prices and delivery times can only be provided through an individual quote.

address:

GMG – Gesellschaft für modulare Greifersysteme mbH
 Rodinger Weg 8H • D-59494 Soest
 Germany

phone:

+49 (0)2921 - 4062

fax:

+49 (0)2921 - 4042

e-mail:

info@gmg-system.com

homepage:

http://www.gmg-system.com