

Positioning by proximity switches:

At least two positions of the fingers can be determined for the control system by mounting of proximity switches in the grooves of both gripper sides. The following types of proximity switches are optionally available:

Proximity switches and their connecting pins:

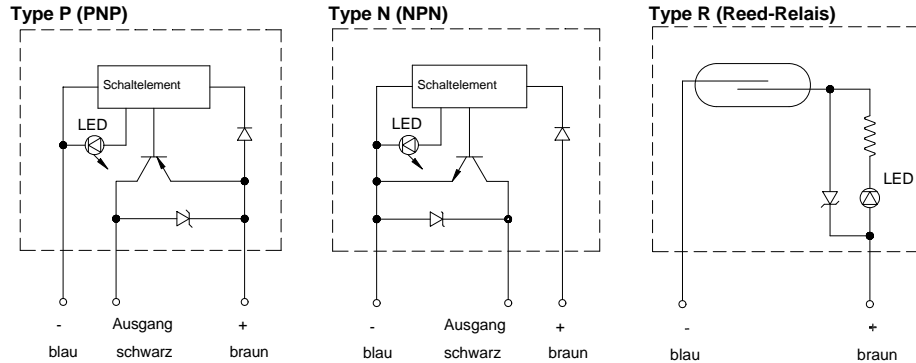

Torque – Rotation-angle – Diagram

(bei 6 bar)

W06

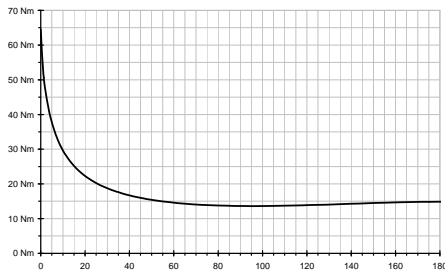

W03

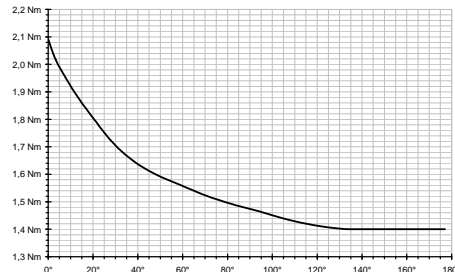

Manual for GMG – Angular Grippers Type W03 and W06

General Information:

Read the manual carefully before usage, follow the instructions and keep this document for further use.

Erroneous and faulty usage, overload or unauthorized changes influence the function, safety and the lifetime of the gripper!

Changes to the gripper will lead to a warranty loss.

Safety Instructions:

Do not touch the gripper while it is connected to air pressure. While assembling, adjusting and working on the gripper, it is mandatory to implement safety regulations so that no fingers or other body parts are in proximity to the moving parts of the gripper.

There is risk and danger of injury.

Maintenance, assembling, adjustments and other works on the gripper, such as, for instance, attachment of top jaws or proximity switches, should only be implemented by skilled and qualified workers when the gripper is not under air-pressure.

Mounting of the gripper:

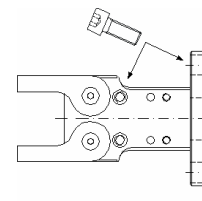

For mounting the gripper onto a robot, a handling device, onto a manipulator or a machine, the gripper body and its flange (if ordered) have bores or through- and tapped holes.

For orientation and fixation of the gripper, there are two fixing (index) bores at each long side of the gripper body and one on the flange (if ordered).

At the back side of the gripper or their flange, if ordered, there is a standard bore H7 for centering the gripper axis.

Design and attachment of top jaws:

Top jaws are intersections between the gripper fingers and the handling parts. They must be designed specifically for each handling part. Therefore they are not part of the scope of delivery.

For the creation of a secure hold the top jaws should be designed in such a form that the connection to the part is a form lock.

If form locking is not possible, there should be use of a wear-resistant elastic material with a high coefficient of friction such as Vulkollan or Polyurethan.

For attachment of the top jaws the gripper fingers have some bores, through or tapped holes and a fixing bore.

The fingers are designed like a double-T-girder. Use the grooves to fix the top jaws against rotation.

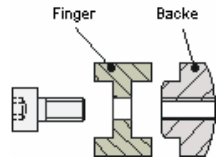

Do not design with redundancy in measurements like double fit or transition fit.

The holding power must constantly be transmitted through the stronger sides of the finger profiles onto the top jaws. The authorized maximum load in X-, Y- and Z-direction may not be exceeded.

Please view the gripper, the catalog or the internet under www.gmg-system.com for measurements of finger profiles and top jaws.

Holding power and height of top jaws:

The holding power depends on the set air pressure and positioning of the fingers. The kinematics of the finger-motion generates a great closing speed with weak holding power at the beginning of the movement. With increasing closing-angle, speed decreases and holding power increases until it reaches its maximum in closed finger-position.

The height of the top jaws is also essential for the holding power.

Principally one should attempt to hold every object with the minimum needed power and to design the top jaws in such manner that a reserve for the closing-angle of the finger is provided.

The natural wear-out in the bearings and on the jaws over time leads to an increase in holding power through the described kinematic. Further, the cycling-time of the gripper decreases, meaning the gripper becomes faster. For this reason, the pneumatic pressure should be decreased with increasing usage time. Otherwise the increasing power can damage the gripper.

Connections and Shock absorption:

The gripper cylinder has a piston working on both sides for pneumatic opening and closing of the gripper. Depending on gripper type, there is existence of at least two air

pressure connections: M5 with W03 and G1/8" with W06. Those connections are covered at plastic of delivery. We recommend to keep the plastic cover to reuse them for future shipping purposes so that no dirt can get into the cylinder.

Connection elements do not belong to the delivery package of the gripper.

The gripper has an emergency damping for the opened position. Nevertheless, we recommend the use of connecting elements with integrated throttle-back-pressure valves, which throttle the exhaust air. Please adjust the exhaust air throttle in a way that the end positions of the finger motion can also be damped by the closing procedure. Every push represents an undefined acceleration of the moveable mass of the gripper parts which generates high stress and tension and finally destroys the parts.

Securing of objects in case of energy failure:

The GMG-gripper mechanisms are not self-inhibiting in their kinematics. For this reason, there has to be object-security for a limited time through a back-pressure valve in the receiving pipe in front of the valve or through usage of 5/3-way-valves with closed middle position. The user has to secure that no persons are within the danger zone under or directly next to the gripper.

To reach maximum speed and minimum cycle times, the valve should be installed next to the gripper.



Usage of the gripper:

After all preceding steps have been implemented and all safety regulations have been considered, the gripper can be used.

The gripper is developed for a maximum usage pressure of $p_{max} = 6 \text{ bar} = 0,6 \text{ N/mm}^2 = 6 \times 10^5 \text{ Pa} = 87 \text{ psi}$. If used with higher pressure, there will be a reduction in the gripper's lifetime, and vice versa.

We recommend the use of a separate air pressure dosage unit for the gripper, so the work pressure of the gripper becomes independent from the entire installation.

Maintenance and lubrication of the gripper:

GMG-grippers hold high-quality maintenance- and lubrication-free sliding bearings. Metallic contacts, which need lubrication, do not exist in the entire system.

The pneumatic cylinder receives long-term lubrication by assembly. The gripper can also be used by non-lubricated air pressure. Air pressure must be free from condensation water.

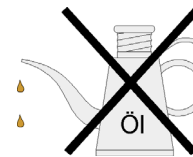



Declaration of manufacturer

According to the latest edition (93/44/EWG, schedule II B) of the EG Machine Instructions:

Herewith we declare that the following GMG gripper models

A-06, B-02, B-10, C-03, C-06, C-10, C-16, E-03, HS-03, WG-03 and WG-06

as delivered, must be installed into a machine, a robot or a handling system.

In addition, do not put the gripper in operation until assured that the machine or robot to which it is connected meets the actual (EG, CSA, FCC) Machine Instructions, especially the latest edition of the safety regulations.

To operate the gripper it is necessary to have particular knowledge about automation and gripper operation.



GMG GmbH

(Company Management)

GMG-Gesellschaft fuer
modulare Greifersysteme mbH
Rodinger Weg 8H
D-59494 Soest
(Germany)

Phone : (0 29 21) 40 62
Fax : (0 29 21) 40 42
CEO's : I. Ruppert, F. Saadat
E-Mail : info@gmg-system.com
Internet : www.gmg-system.com

Banking:
Volksbank Hellweg eG
Account-No. : 3224045500
Swift Code: GENO DE M1 SOE
IBAN :DE23414601163224045500

Inferior Court: Arnsberg
Register-No.: 5749
Tax-Id.-No.: DE 162272004
DUNS-No.: 344085634
Tax No.: 343 / 5805 / 0330